

### MODEL NUMBER IDENTIFICATION

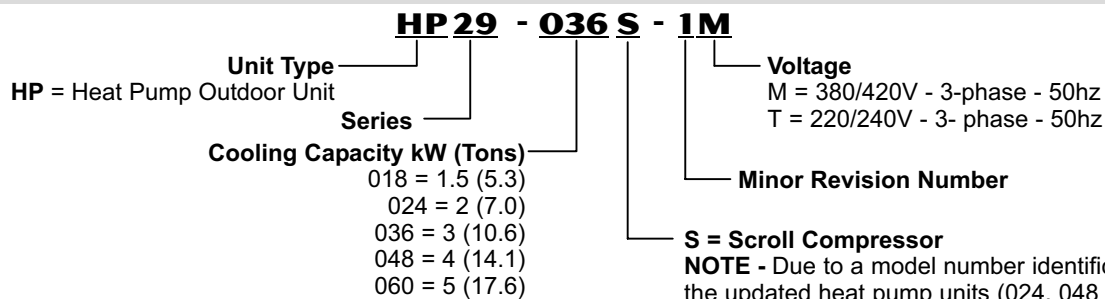

**NOTE** - Due to a model number identification change, many of the updated heat pump units (024, 048 and 060) will contain a scroll compressor but will no longer include the "S" designation.

### FEATURES

#### CONTENTS

Rating Tables .....	Pages 5-6
Dimensions .....	Page 7
Expanded Rating Tables .....	Pages 8-19
Electrical Data .....	Pages 3-4
Features .....	Pages 1-2
Field Wiring .....	Page 4
Installation Clearances .....	Page 3
Model Number Identification .....	Page 1
Optional Accessories .....	Page 2
Specifications .....	Pages 3-4

#### APPLICATIONS

Vertical air discharge allows concealment behind shrubs at grade level or out of sight on a roof. Matching up-flow, down-flow and horizontal blower coil units with supplemental electric heat provide a wide range of cooling and heating capacities and applications. See ratings table for match-ups. For indoor blower coil unit data, see Coils - Blower Coil Units, this section. Units shipped completely factory assembled, piped and wired. Each unit is test operated at the factory insuring proper operation. Installer must set outdoor unit, connect refrigerant lines and make electrical connections to complete job.

Visit us at [www.lennox.com](http://www.lennox.com)  
 For the latest technical information, [www.lennox.com](http://www.lennox.com)

## FEATURES

### COMPLETELY TESTED

Tested in the Lennox Research Laboratory environmental test rooms which meet American Society of Heating, Refrigeration and Air-Conditioning Engineers (ASHRAE) Standard 37 requirements.

Rating test conditions are those included in Air-Conditioning and Refrigeration Institute (ARI) Standard 210/240 while operating at rated voltages and air volumes.

Sound rated in Lennox reverberant sound test room in accordance with test conditions for Air-Conditioning and Refrigeration Institute (ARI) Standard 270-95.

Condensing units and components within bonded for grounding to meet safety standards for servicing required by Underwriters Laboratories (U.L.) and the International Electrotechnical Commission (IEC).

ISO 9001 Registered Manufacturing Quality System.

### REFRIGERANT SYSTEM

#### Reversing Valve

Factory installed 4-way reversing valve provides rapid change in refrigerant flow direction resulting in quick changeover from cooling to heating and vice-versa.

Valve operates on pressure differential between outdoor unit and indoor unit.

#### Copper Tube/Enhanced Fin Coil

Lennox designed and fabricated coil.

Ripple-edged aluminum fins.

Copper tube construction.

Lanced fins provide maximum exposure of fin surface to air stream resulting in excellent heat transfer.

Fin collars grip tubing for maximum contact area.

Flared shoulder tubing connections/silver soldering construction.

Coil is factory tested under high pressure to insure leakproof construction.

Entire coil is accessible for cleaning.

Polyvinyl Chloride (PVC) coated steel wire coil guard furnished as standard.

#### Outdoor Coil Fan

Direct drive fan moves large air volumes uniformly through entire outdoor coil for high refrigerant cooling capacity.

Vertical air discharge minimizes operating sounds and eliminates damage to lawn and shrubs.

Fan motor has sleeve bearings and is inherently protected.

Motor totally enclosed for maximum protection from weather, dust and corrosion.

Rain shield on motor provides additional protection from moisture.

Louvered steel top fan guard furnished as standard.

Fan service access accomplished by removal of fan guard.

#### Expansion Valve

Factory installed and piped expansion valve is designed and sized specifically for use in heat pump system.

Sensing bulb is located on suction line between reversing valve and compressor to sense suction temperature in any cycle.

#### Hi-Capacity Drier

Factory installed.

Drier traps any moisture or dirt that could contaminate the refrigerant system.

### CONTROLS

#### Defrost Control

Solid-state time/temperature defrost control is furnished as standard equipment.

Control initiates a defrost cycle every 30, 60 or 90 minutes of compressor "on" time at outdoor temperatures below 2°C (35° F) (factory setting 60 minutes).

Maximum defrost cycle 14 minutes.

Defrost thermostat mounted on liquid line determines when defrost cycle is required and when to terminate cycle.

#### High Pressure Switch

Automatic reset switch shuts off unit if abnormal operating conditions cause discharge pressure to rise above setting.

### Start Controls

Furnished on HP29-024 units.

Provides assistance for compressor start under loaded conditions or in case of low voltage.

### COMPRESSORS

#### Reciprocating Compressor (HP29-018)

Designed for dependable efficiency with minimum operating cost. Suction cooled and overload protected with internal pressure relief. Hermetically sealed with built-in protection from excessive current and temperatures.

Crankcase heater assures proper compressor lubrication.

Running gear assembly resiliently suspended internally inside case. Compressor installed in unit on resilient rubber mounts assuring low sound and vibration free operation.

#### Copeland® Compliant Scroll Compressor (HP29-024-036S-048-060)

Compressor features high efficiency with uniform suction flow, constant discharge flow and high volumetric efficiency and quiet operation.

Compressor consists of two involute spiral scrolls matched together to generate a series of crescent shaped gas pockets between them.

During compression, one scroll remains stationary while the other scroll orbits around it.

Gas is drawn into the outer pocket, the pocket is sealed as the scroll rotates.

As the spiral movement continues, gas pockets are pushed to the center and the space between the pockets is simultaneously reduced.

When pocket reaches the center, gas is now at high pressure and is forced out of a port located in the center of the fixed scrolls. During compression, several pockets are compressed simultaneously resulting in a smooth continuous compression cycle.

Continuous flank contact, maintained by centrifugal force, minimizes gas leakage and maximizes efficiency.

Scroll compressor is tolerant to the effects of slugging and contaminants. If this occurs, scrolls separate, allowing liquid or contaminants to be worked toward the center and discharged.

Low gas pulses during compression reduces operational sound levels.

Compressor motor is internally protected from excessive current and temperature.

Compressor is installed in the unit on resilient rubber mounts for vibration free operation.



### CABINET

Heavy gauge steel cabinet with five station metal wash process.

Powder paint finish provides rust and corrosion protection.

Painted base section.

Control box is conveniently located with all controls factory wired.

Corner patch plate allows access to compressor.

Drainage holes are provided in base section for moisture removal.

#### Refrigerant Line Connections, Electrical Inlets, Service Valves

Sweat connection suction and liquid lines are located on corner of unit cabinet.

Fully serviceable brass service valves prevent corrosion and provide access to refrigerant system. Suction valve can be fully shut off, while liquid valve may be front seated to manage refrigerant charge while servicing system.

45° elbow furnished for ease of suction line connection.

HP29-024 models are stubbed with 9.5 mm (3/8 in.) liquid line connection. 9.5 mm x 7.9 mm (3/8 in. x 5/16 in.) reducer bushing furnished with for liquid line connection.

Refrigerant line connections and field wiring inlets are located in one central area of cabinet for easy access. See dimension drawing.

## OPTIONAL ACCESSORIES - MUST BE ORDERED EXTRA

### Thermostat

Thermostat not furnished with unit. See Lennox Price Book.

### Refrigerant Line Kits

Refrigerant lines (suction & liquid) are shipped refrigeration clean.

Lines are cleaned, dried, pressurized and sealed at factory.

Suction line fully insulated.

L15 lines are stubbed at both ends.

### Low Ambient Kit

Outdoor units operate satisfactorily in the cooling mode down to 7°C (45°F) outdoor air temperature without any additional controls.

Low Ambient Control Kit can be field installed, allowing proper unit operation in the cooling mode down to -1°C (30°F).

### Unit Stand-Off Kit

Black high density polyethylene feet are available to raise unit off of mounting surface away from damaging moisture.

Four feet are furnished per order number.

### Freezestat

Installs on or near the discharge line of the evaporator or on the suction line.

Senses suction line temperature and cycles the compressor off when suction line temperature falls below it's setpoint.

## SPECIFICATIONS

General Data		Model Number	HP29-018	HP29-024	HP29-036S	HP29-048	HP29-060
Nominal kW (Tonnage)			5.3 (1.5)	7.0 (2)	10.6 (3)	14.1 (4)	17.6 (5)
Connections (sweat)	Liquid line - outside diameter - mm (in.)		<sup>1</sup> 9.5 (3/8)	<sup>1</sup> 9.5 (3/8)	9.5 (3/8)	9.5 (3/8)	9.5 (3/8)
	Vapor line - outside diameter - mm (in.)		15.9 (5/8)	19.1 (3/4)	19.1 (3/4)	22.2 (7/8)	28.6 (1-1/8)
<sup>2</sup> Refrigerant (HCFC-22) furnished - kg (oz.)			1.93 (68)	1.93 (68)	3.32 (117)	4.05 (143)	5.44 (192)
Outdoor Coil	Net face area - m <sup>2</sup> (ft. <sup>2</sup> ) - Outer coil		1.06 (11.41)	1.06 (11.41)	1.41 (15.21)	1.41 (15.21)	1.96 (21.11)
	Inner coil		----	----	1.35 (14.5)	1.35 (14.5)	1.89 (20.31)
	Tube outside diameter - mm (in.)		7.9 (5/16)	7.9 (5/16)	7.9 (5/16)	7.9 (5/16)	7.9 (5/16)
	Number of rows		1	1	2	2	2
Outdoor Coil Fan	Fins per m (inch)		866 (22)	866 (22)	709 (18)	709 (18)	866 (22)
	Diameter - mm (in.)		457 (18)	457 (18)	457 (18)	457 (18)	559 (22)
	Number of blades		3	3	4	4	4
	Motor output - W (hp)		125 (1/6)	125 (1/6)	125 (1/6)	250 (1/3)	250 (1/3)
Shipping Data - lbs. (kg) 1 package	Air volume - L/s (cfm)		945 (2000)	945 (2000)	985 (2085)	1190 (2520)	1705 (3610)
	Rev/Min		920	920	920	940	900
	Motor input - W		140	140	155	255	320
Shipping Data - lbs. (kg) 1 package			69 (152)	69 (152)	86 (190)	86 (190)	115 (254)

## ELECTRICAL DATA

Electrical Data (50 hz)		Line voltage data	220/240V 1 phase	220/240V 1 phase	220/240V 1 phase	380/420V 3 phase	<sup>4</sup> 380/420V 3 phase	<sup>4</sup> 380/420V 3 phase
Voltage range (minimum - maximum)			198 - 264 V	198 - 264 V	198 - 264 V	342 - 462 V	342 - 462 V	342 - 462 V
<sup>3</sup> Maximum overcurrent protection (amps)			15	20	30	10	15	20
Minimum circuit ampacity			11.1	13.9	19.3	6.9	10.2	12.2
Compressor	Rated load amps		8.1	10.3	14.7	5.1	8.2	10
	Locked rotor amps		44	58	82	40	50	62
Outdoor Coil Fan Motor	Full load amps		1.0	1.0	1.0	0.5	0.7	0.7
	Locked rotor amps		1.9	1.9	1.9	0.9	1.8	1.8

## OPTIONAL ACCESSORIES - MUST BE ORDERED EXTRA

Freezestat	3/8 in. tubing	<b>93G35</b>	<b>93G35</b>	<b>93G35</b>	<b>93G35</b>	<b>93G35</b>
	1/2 in. tubing	<b>39H29</b>	<b>39H29</b>	<b>39H29</b>	<b>39H29</b>	<b>39H29</b>
	5/8 in. tubing	<b>50A93</b>	<b>50A93</b>	<b>50A93</b>	<b>50A93</b>	<b>50A93</b>
Low Ambient Kit		<b>27J00</b>	<b>27J00</b>	<b>27J00</b>	<b>27J00</b>	<b>27J00</b>
Refrigerant Line Set	15 ft. (6 m) length	L15-21-15	L15-41-15	L15-41-15	L15-65-15	Field Fabricate
	20 ft. (6 m) length	L15-21-20	L15-41-20	L15-41-20	---	Field Fabricate
	25 ft. (8 m) length	L15-21-25	---	---	---	Field Fabricate
	30 ft. (9 m) length	---	L15-41-30	L15-41-30	L15-65-30	Field Fabricate
	35 ft. (10.6 m) length	L15-21-35	---	---	---	Field Fabricate
	40 ft. (12 m) length	---	L15-41-40	L15-41-40	L15-65-40	Field Fabricate
Unit Stand-Off Kit		<b>94J45</b>	<b>94J45</b>	<b>94J45</b>	<b>94J45</b>	<b>94J45</b>

NOTE - Refer to local electrical codes to determine wire, fuse and disconnect size requirements.

<sup>1</sup> 3/8 x 5/16 in. (9.5 x 7.9 mm) adaptor furnished for liquid line connection.

<sup>2</sup> Refrigerant charge is sufficient for 15 ft. (4.6 m) length line set.

<sup>3</sup> HACR type breaker or fuse.

<sup>4</sup> Neutral required with optional Transformer Kit (16F34).

## RATINGS

Outdoor Unit Model No. Unit Size <sup>1</sup> Sound Rating Number	<sup>2</sup> Net Heating and Cooling Ratings												Indoor Unit Model No.	Check and Expansion Valve Kit Required	
	Cooling Capacity		High Temp. Heating Capacity		Low Temp. Heating Capacity		Cooling			High Temperature Heating		Low Temperature Heating			
	kW	Btuh	kW	Btuh	kW	Btuh	Total Power Input kW	<sup>3</sup> C.O.P.	<sup>4</sup> EER	Total Power Input kW	<sup>3</sup> C.O.P.	Total Power Input kW			<sup>3</sup> C.O.P.
<b>HP29-018</b> 1.5 Ton (76 dB)	4.8	16 300	4.6	15 600	2.8	9400	1.65	2.90	9.90	1.5	3.16	1.4	1.9	CB29M-21/26 (Mult-Position)	Factory Installed
<b>HP29-024</b> 2 Ton (76 dB)	5.9	20 100	5.8	19 700	3.4	11 700	2.20	2.68	9.15	1.8	3.12	1.5	2.23	CB29M-21/26 (Mult-Position)	Factory Installed
<b>HP29-036S</b> 3 Ton (76 dB)	9.0	30 700	9.0	30 800	5.1	17 400	3.25	2.77	9.44	2.7	3.35	2.2	2.35	CB29M-31/41 (Mult-Position)	Factory Installed
<b>HP29-048</b> 4 Ton (84 dB)	12.2	41 700	11.0	37 700	6.4	22 000	4.39	2.78	9.50	3.5	3.19	2.7	2.34	CB29M-51 (Mult-Position)	Factory Installed
<b>HP29-060</b> 5 Ton (84 dB)	14.4	49 300	14.4	49 100	9.0	30 700	5.80	2.49	8.51	4.5	3.16	4.1	2.17	CB29M-65 (Mult-Position)	Factory Installed

<sup>1</sup> Sound rating number rated at test conditions for Air-Conditioning and Refrigeration Institute (ARI) Standard 270.

<sup>2</sup> The rating test conditions are those included in Air-Conditioning and Refrigeration Institute (ARI) Standard 210/240-89 while operating at rated voltage and air volumes;

**Cooling Ratings** - 35°C (95°F) outdoor air temperature, 26.7°C (80°F) dry bulb and 19.4°C (67°F) wet bulb entering indoor coil air.

**High Temperature Heating Ratings** - 8.3°C (47°F) dry bulb, 6.1°C (43°F) wet bulb outdoor air temperature and 21.1°C (70°F) entering indoor coil air.

**Low Temperature Heating Ratings** - minus 8.3°C (17°F) dry bulb, minus 9.4°C (15°F) wet bulb outdoor air temperature and 21.1°C (70°F) entering indoor coil air.

<sup>3</sup> C.O.P. = Coefficient of Performance (Output/Input)

<sup>4</sup> EER = Energy Efficiency Ratio (Btuh/Watt)

## FIELD WIRING

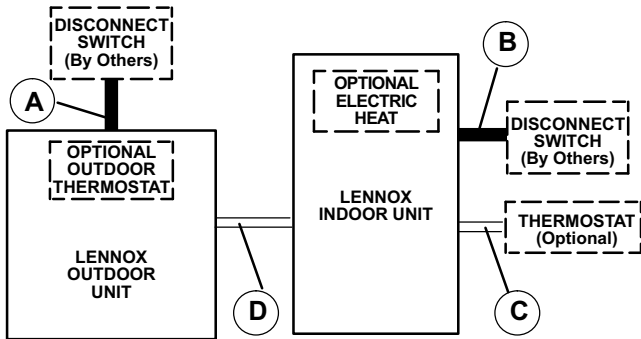

- A — Single Or Three Phase With Neutral (see Electrical Data)
- B — Single Phase (size to heater capacity)
- C — Twelve Wire Low Voltage — 18 ga. minimum
  - Fourteen Wire Low Voltage with Optional Outdoor Thermostat
- D — Eight Wire Low Voltage — 18 ga. minimum
  - Ten Wire Low Voltage with Optional Outdoor Thermostat

— Field Wiring Not Furnished —

All wiring must conform to local electrical codes.

## INSTALLATION CLEARANCES - MM (IN.)

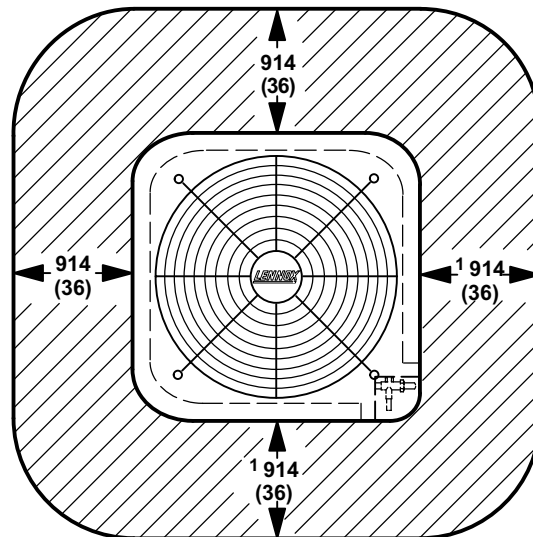

NOTE—1219 mm (48 in.) clearance required on top of unit.

<sup>1</sup> NOTE—One side must be 914 mm (36 in.) for service. Two of the remaining three sides may be 305 mm (12 in.).

**DIMENSIONS – MM (INCHES)**

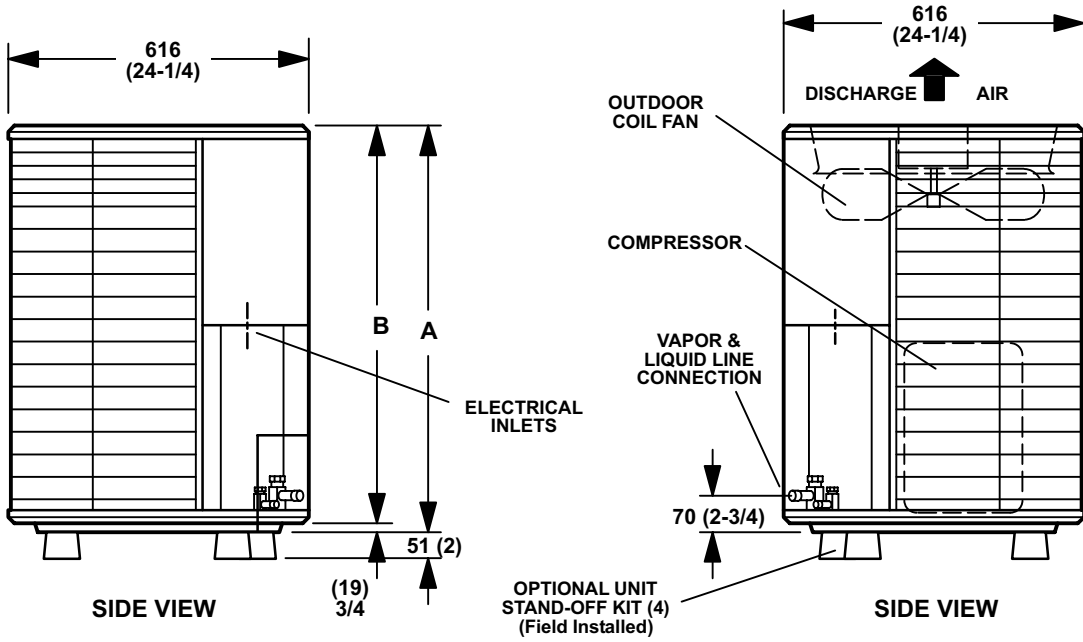
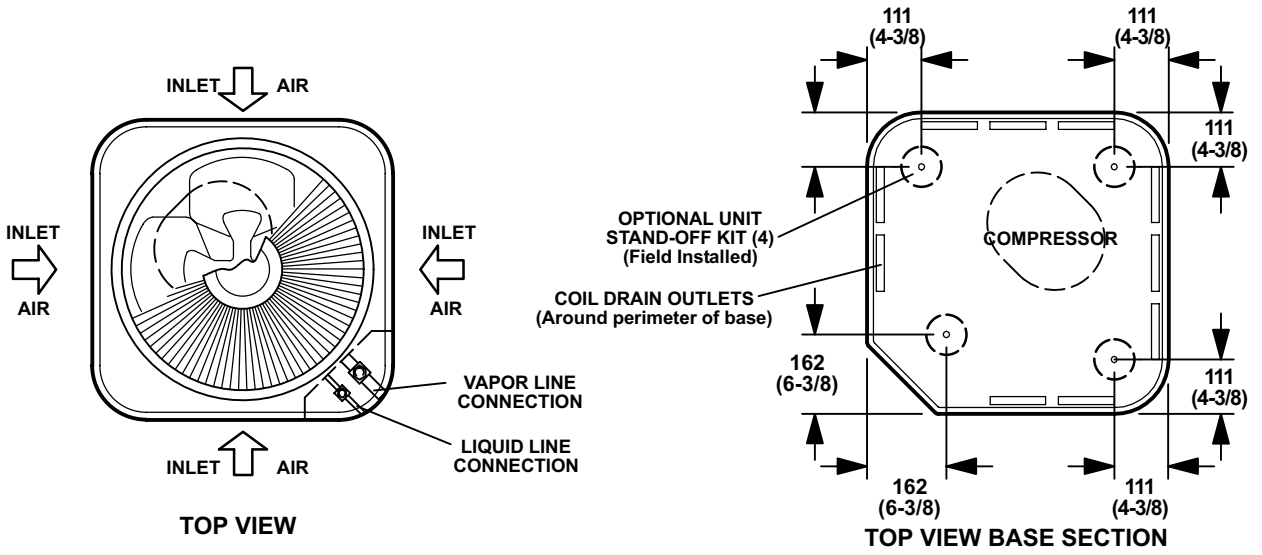

Model Number		A	B
HP29-018	mm	641	616
HP29-024	in.	25-1/4	24-1/4
HP29-036S	mm	845	819
HP29-048	in.	33-1/4	32-1/4
HP29-060	in.	33-1/4	32-1/4

# COOLING AND HEATING RATINGS – 50HZ

NOTE — For Temperatures and Capacities not shown in tables, see bulletin — Cooling Unit Rating Table Correction Factor Data in Miscellaneous Engineering Data Section.

## HP29-018 — CB29M-21/26 - COOLING CAPACITY

Entering Wet Bulb Temperature	Total Air Volume		Outdoor Air Temperature Entering Outdoor Coil																							
			29°C (85°F)						35°C (95°F)						41°C (105°F)						46°C (115°F)					
			Total Cooling Capacity		Comp Motor kW Input	Sensible To Total Ratio (S/T)			Total Cooling Capacity		Comp Motor kW Input	Sensible To Total Ratio (S/T)			Total Cooling Capacity		Comp Motor kW Input	Sensible To Total Ratio (S/T)			Total Cooling Capacity		Comp Motor kW Input	Sensible To Total Ratio (S/T)		
						Dry Bulb						Dry Bulb						Dry Bulb						Dry Bulb		
m <sup>3</sup> /s	cfm	kW	kBtu/h	24°C 75°F	27°C 80°F	29°C 85°F	kW	kBtu/h	24°C 75°F	27°C 80°F	29°C 85°F	kW	kBtu/h	24°C 75°F	27°C 80°F	29°C 85°F	kW	kBtu/h	24°C 75°F	27°C 80°F	29°C 85°F	kW	kBtu/h	24°C 75°F	27°C 80°F	29°C 85°F
17°C (63°F)	.25	535	4.9	16.7	1.18	.75	.89	1.00	4.6	15.8	1.28	.77	.91	1.00	4.4	14.9	1.38	.79	.94	1.00	4.1	14.1	1.48	.81	.97	1.00
	.27	580	5.0	17.0	1.19	.77	.91	1.00	4.7	16.1	1.29	.79	.93	1.00	4.5	15.2	1.39	.81	.96	1.00	4.2	14.3	1.49	.83	.99	1.00
19°C (67°F)	.24	580	5.2	17.9	1.21	.61	.74	.87	5.0	17.0	1.31	.62	.76	.90	4.7	16.1	1.42	.63	.78	.93	4.4	15.1	1.52	.65	.81	.96
	.27	730	5.5	18.7	1.23	.64	.79	.94	5.2	17.8	1.33	.65	.82	.96	4.9	16.8	1.44	.67	.84	.99	4.6	15.8	1.54	.68	.87	1.00
22°C (71°F)	.25	535	5.4	18.3	1.22	.46	.59	.70	5.1	17.4	1.32	.46	.60	.72	4.9	16.6	1.43	.47	.61	.74	4.6	15.6	1.54	.47	.62	.76
	.27	580	5.5	18.7	1.23	.46	.60	.72	5.2	17.8	1.33	.47	.61	.74	5.0	16.9	1.44	.47	.62	.76	4.7	15.9	1.55	.48	.63	.78
	.34	730	5.7	19.6	1.24	.48	.63	.77	5.5	18.6	1.35	.48	.64	.79	5.2	17.6	1.46	.49	.65	.82	4.9	16.6	1.57	.50	.67	.85

## HP29-018 — CB29M-21/26 - HEATING CAPACITY

Indoor Coil Air Volume 21°C db (70°F db)		Air Temperature Entering Outdoor Coil														
		18°C (65°F)			7°C (45°F)			minus 4°C (25°F)			minus 15°C (5°F)			minus 28°C (minus 15°F)		
		Total Heating Capacity		Comp. Motor kW Input	Total Heating Capacity		Comp. Motor kW Input	Total Heating Capacity		Comp. Motor kW Input	Total Heating Capacity		Comp. Motor kW Input	Total Heating Capacity		Comp. Motor kW Input
kW	kBtu/h	kW	kBtu/h		kW	kBtu/h		kW	kBtu/h		kW	kBtu/h				
m <sup>3</sup> /s	cfm	kW	kBtu/h	kW	kBtu/h	kW	kBtu/h	kW	kBtu/h	kW	kBtu/h	kW	kBtu/h	kW	kBtu/h	
0.26	535	5.6	19.1	1.13	4.4	14.9	1.11	3.1	10.7	1.08	2.0	6.9	1.05	1.0	3.5	.76
0.28	580	5.7	19.3	1.12	4.4	15.1	1.09	3.2	10.9	1.06	2.1	7.1	1.04	1.1	3.7	.74
0.35	730	5.8	19.8	1.08	4.6	15.6	1.06	3.3	11.4	1.03	2.2	7.6	1.00	1.2	4.2	.71

## HP29-024 — COOLING CAPACITY — CB29M-21/26

Entering Wet Bulb Temperature	Total Air Volume		Outdoor Temperature																							
			29°C (85°F)						35°C (95°F)						41°C (105°F)						46°C (115°F)					
			Total Cooling Capacity		Compressor Motor	Sensible To Total Ratio (S/T)			Total Cooling Capacity		Compressor Motor	Sensible To Total Ratio (S/T)			Total Cooling Capacity		Compressor Motor	Sensible To Total Ratio (S/T)			Total Cooling Capacity		Compressor Motor	Sensible To Total Ratio (S/T)		
						Dry Bulb						Dry Bulb						Dry Bulb						Dry Bulb		
L/s	cfm	kW	Btu/h	kW	24°C 75°F	27°C 80°F	29°C 85°F	kW	Btu/h	kW	24°C 75°F	27°C 80°F	29°C 85°F	kW	Btu/h	kW	24°C 75°F	27°C 80°F	29°C 85°F	kW	Btu/h	kW	24°C 75°F	27°C 80°F	29°C 85°F	
17.2°C (63°F)	305	650	6.0	20 400	1.60	.75	.89	.99	5.7	19 300	1.71	.77	.91	1.00	5.3	18 100	1.81	.79	.94	1.00	5.0	16 900	1.91	.82	.97	1.00
	380	800	6.2	21 200	1.62	.80	.95	1.00	5.9	20 000	1.74	.82	.97	1.00	5.5	18 900	1.85	.85	.99	1.00	5.2	17 700	1.95	.88	1.00	1.00
	450	950	6.4	21 800	1.64	.85	.99	1.00	6.1	20 700	1.76	.87	1.00	1.00	5.7	19 600	1.88	.90	1.00	1.00	5.4	18 400	1.99	.93	1.00	1.00
19.4°C (67°F)	305	650	6.4	21 800	1.64	.58	.72	.86	6.0	20 500	1.76	.59	.74	.88	5.7	19 300	1.86	.60	.76	.91	5.3	18 000	1.96	.62	.79	.94
	380	800	6.6	22 400	1.66	.61	.77	.92	6.2	21 100	1.78	.62	.80	.94	5.8	19 800	1.89	.64	.82	.97	5.4	18 500	1.99	.66	.85	.99
	450	950	6.7	22 900	1.67	.64	.82	.97	6.3	21 600	1.79	.66	.85	.99	5.9	20 200	1.90	.68	.88	1.00	5.5	18 800	2.01	.70	.91	1.00
21.7°C (71°F)	305	650	6.9	23 400	1.68	.43	.56	.69	6.5	22 100	1.81	.43	.57	.71	6.1	20 700	1.92	.44	.59	.74	5.7	19 300	2.03	.44	.60	.76
	380	800	7.0	24 000	1.70	.44	.59	.75	6.6	22 600	1.82	.45	.61	.77	6.2	21 200	1.94	.45	.63	.80	5.8	19 700	2.05	.46	.65	.83
	450	950	7.2	24 400	1.71	.45	.63	.80	6.7	23 000	1.84	.46	.64	.83	6.3	21 600	1.96	.47	.67	.85	5.9	20 100	2.07	.48	.69	.89

## HP29-024 — HEATING CAPACITY — CB29M-21/26

Indoor Coil Air Volume 70°F db (21°C db)		Air Temperature Entering Outdoor Coil														
		65°F (18°C)			45°F (7°C)			25°F (-4°C)			5°F (-15°C)			-15°F (-28°C)		
		Total Heating Capacity		Comp. Motor Watts Input	Total Heating Capacity		Comp. Motor Watts Input	Total Heating Capacity		Comp. Motor Watts Input	Total Heating Capacity		Comp. Motor Watts Input	Total Heating Capacity		Comp. Motor Watts Input
kW	Btu/h	kW	Btu/h		kW	Btu/h		kW	Btu/h		kW	Btu/h				
L/s	cfm	kW	Btu/h	Comp. Motor Watts Input	kW	Btu/h	Comp. Motor Watts Input	kW	Btu/h	Comp. Motor Watts Input	kW	Btu/h	Comp. Motor Watts Input	kW	Btu/h	Comp. Motor Watts Input
305	650	7.0	23 900	1675	5.4	18 300	1430	3.6	12 400	1180	2.5	8 500	965	1.2	4 000	730
380	800	7.2	24 500	1640	5.5	18 900	1395	3.8	13 000	1145	2.7	9 100	930	1.3	4 600	695
450	950	7.3	25 000	1615	5.7	19 400	1370	4.0	13 500	1120	2.8	9 600	905	1.5	5 100	670

NOTE — Heating capacities include the effect of defrost cycles in the temperature range where they occur.

# COOLING AND HEATING RATINGS – 50HZ

NOTE — For Temperatures and Capacities not shown in tables, see bulletin — Cooling Unit Rating Table Correction Factor Data in Miscellaneous Engineering Data Section.

## HP29-036S — COOLING CAPACITY — CB29M-31/41

Entering Wet Bulb Temperature	Total Air Volume		Outdoor Temperature																							
			29°C (85°F)						35°C (95°F)						41°C (105°F)						46°C (115°F)					
			Total Cooling Capacity		Compressor Motor	Sensible To Total Ratio (S/T)			Total Cooling Capacity		Compressor Motor	Sensible To Total Ratio (S/T)			Total Cooling Capacity		Compressor Motor	Sensible To Total Ratio (S/T)			Total Cooling Capacity		Compressor Motor	Sensible To Total Ratio (S/T)		
						Dry Bulb						Dry Bulb						Dry Bulb						Dry Bulb		
L/s	cfm	kW	Btuh	kW	24°C 75°F	27°C 80°F	29°C 85°F	kW	Btuh	kW	24°C 75°F	27°C 80°F	29°C 85°F	kW	Btuh	kW	24°C 75°F	27°C 80°F	29°C 85°F	kW	Btuh	kW	24°C 75°F	27°C 80°F	29°C 85°F	
17.2°C (63°F)	470	1000	9.1	31 200	2.38	.74	.88	.98	8.7	29 600	2.55	.75	.90	1.00	8.2	27 900	2.72	.77	.92	1.00	7.6	26 100	2.87	.80	.95	1.00
	565	1200	9.4	32 100	2.41	.78	.93	1.00	8.9	30 500	2.59	.80	.95	1.00	8.4	28 800	2.76	.82	.97	1.00	7.9	27 100	2.93	.85	.99	1.00
	660	1400	9.7	33 000	2.44	.82	.97	1.00	9.2	31 300	2.62	.84	.99	1.00	8.7	29 700	2.81	.87	1.00	1.00	8.2	28 000	2.99	.90	1.00	1.00
19.4°C (67°F)	470	1000	9.7	33 200	2.44	.57	.71	.84	9.2	31 500	2.63	.58	.73	.86	8.7	29 700	2.81	.59	.75	.89	8.1	27 700	2.97	.61	.77	.92
	565	1200	10.0	34 000	2.47	.60	.75	.90	9.4	32 200	2.66	.61	.77	.92	8.9	30 300	2.84	.62	.80	.95	8.3	28 400	3.01	.64	.83	.97
	660	1400	10.1	34 600	2.49	.62	.80	.94	9.6	32 800	2.68	.64	.82	.97	9.1	30 900	2.87	.65	.84	.99	8.5	28 900	3.04	.67	.88	1.00
21.7°C (71°F)	470	1000	10.4	35 400	2.51	.43	.56	.68	9.8	33 600	2.71	.43	.57	.70	9.3	31 700	2.91	.43	.58	.72	8.7	29 700	3.09	.44	.59	.75
	565	1200	10.6	36 300	2.53	.44	.58	.73	10.1	34 400	2.74	.44	.60	.75	9.5	32 400	2.94	.45	.61	.77	8.9	30 300	3.13	.45	.63	.80
	660	1400	10.8	36 800	2.54	.45	.61	.77	10.2	34 900	2.76	.45	.63	.80	9.6	32 900	2.96	.46	.64	.82	9.0	30 700	3.15	.47	.66	.85

## HP29-036S — HEATING CAPACITY — CB29M-31/41

Indoor Coil Air Volume 70°F db (21°C db)	Air Temperature Entering Outdoor Coil																			
	65°F (18°C)				45°F (7°C)				25°F (-4°C)				5°F (-15°C)				-15°F (-28°C)			
	Total Heating Capacity		Comp. Motor Watts Input	Total Heating Capacity		Comp. Motor Watts Input	Total Heating Capacity		Comp. Motor Watts Input	Total Heating Capacity		Comp. Motor Watts Input	Total Heating Capacity		Comp. Motor Watts Input	Total Heating Capacity		Comp. Motor Watts Input		
																			kW	Btuh
L/s	cfm	kW	Btuh	kW	Btuh	kW	Btuh	kW	Btuh	kW	Btuh	kW	Btuh	kW	Btuh	kW	Btuh			
470	1000	11.1	38 000	2455	8.3	28 200	2110	5.2	17 800	1765	3.7	12 600	1410	1.8	6 100	1070				
565	1200	11.4	38 800	2415	8.5	29 000	2070	5.5	18 600	1725	3.9	13 400	1370	2.0	6 900	1030				
660	1400	11.5	39 400	2380	8.7	29 600	2035	5.6	19 200	1690	4.1	14 000	1335	2.2	7 500	995				

NOTE — Heating capacities include the effect of defrost cycles in the temperature range where they occur.

## HP29-048 — CB29-51M - COOLING CAPACITY

Entering Wet Bulb Temperature	Total Air Volume		Outdoor Air Temperature Entering Outdoor Coil																							
			29°C (85°F)						35°C (95°F)						41°C (105°F)						46°C (115°F)					
			Total Cooling Capacity		Comp Motor kW Input	Sensible To Total Ratio (S/T)			Total Cooling Capacity		Comp Motor kW Input	Sensible To Total Ratio (S/T)			Total Cooling Capacity		Comp Motor kW Input	Sensible To Total Ratio (S/T)			Total Cooling Capacity		Comp Motor kW Input	Sensible To Total Ratio (S/T)		
						Dry Bulb						Dry Bulb						Dry Bulb						Dry Bulb		
m³/s	cfm	kW	kBtuh	kW	24°C 75°F	27°C 80°F	29°C 85°F	kW	kBtuh	kW	24°C 75°F	27°C 80°F	29°C 85°F	kW	kBtuh	kW	24°C 75°F	27°C 80°F	29°C 85°F	kW	kBtuh	kW	24°C 75°F	27°C 80°F	29°C 85°F	
17°C (63°F)	.66	1400	12.3	41.8	3.16	.78	.94	1.00	11.8	40.2	3.57	.80	.95	1.00	11.3	38.6	4.03	.82	.97	1.00	10.8	37.0	4.56	.83	.99	1.00
	.75	1600	12.5	42.8	3.18	.82	.97	1.00	12.1	41.2	3.58	.84	.99	1.00	11.6	39.6	4.04	.86	1.00	1.00	11.2	38.1	4.58	.87	1.00	1.00
	.85	1800	12.8	43.7	3.19	.86	1.00	1.00	12.4	42.2	3.60	.87	1.00	1.00	11.9	40.7	4.07	.89	1.00	1.00	11.5	39.1	4.60	.91	1.00	1.00
19°C (67°F)	.66	1400	13.0	44.3	3.20	.60	.76	.91	12.5	42.5	3.61	.61	.77	.92	11.9	40.7	4.07	.62	.79	.94	11.4	38.9	4.60	.63	.81	.96
	.75	1600	13.2	45.0	3.21	.62	.80	.95	12.7	43.2	3.62	.64	.81	.96	12.1	41.4	4.09	.65	.83	.98	11.6	39.6	4.61	.66	.85	.99
	.85	1800	13.4	45.6	3.22	.65	.83	.98	12.8	43.8	3.63	.66	.85	.99	12.3	41.9	4.09	.67	.87	1.00	11.8	40.1	4.62	.69	.89	1.00
22°C (71°F)	.66	1400	13.9	47.3	3.25	.44	.59	.73	13.3	45.4	3.66	.44	.60	.75	12.7	43.5	4.13	.44	.61	.77	12.2	41.6	4.65	.45	.62	.79
	.75	1600	14.1	48.0	3.26	.45	.61	.78	13.5	46.1	3.67	.45	.62	.79	12.9	44.1	4.14	.46	.63	.81	12.3	42.1	4.66	.46	.65	.83
	.85	1800	14.2	48.5	3.27	.46	.64	.81	13.7	46.6	3.69	.46	.65	.83	13.1	44.6	4.15	.47	.66	.85	12.5	42.6	4.68	.47	.68	.87

## HP29-048 — CB29M-51 - HEATING CAPACITY

Indoor Coil Air Volume 21°C db (70°F db)	Air Temperature Entering Outdoor Coil																			
	18°C (65°F)				7°C (45°F)				minus 4°C (25°F)				minus 15°C (5°F)				minus 28°C (minus 15°F)			
	Total Heating Capacity		Comp. Motor kW Input	Total Heating Capacity		Comp. Motor kW Input	Total Heating Capacity		Comp. Motor kW Input	Total Heating Capacity		Comp. Motor kW Input	Total Heating Capacity		Comp. Motor kW Input	Total Heating Capacity		Comp. Motor kW Input		
																			kW	kBtuh
m³/s	cfm	kW	kBtuh	kW	kBtuh	kW	kBtuh	kW	kBtuh	kW	kBtuh	kW	kBtuh	kW	kBtuh	kW	kBtuh			
.66	1400	14.2	48.3	3.07	11.2	38.2	2.82	8.2	27.9	2.56	5.6	19.1	2.24	2.8	9.5	1.66				
.75	1600	14.3	48.8	2.98	11.3	38.7	2.73	8.3	28.4	2.47	5.7	19.6	2.15	2.9	10.0	1.57				
.85	1800	14.4	49.3	2.91	11.5	39.2	2.66	8.5	28.9	2.40	5.9	20.1	2.08	3.1	10.5	1.50				

# COOLING AND HEATING RATINGS – 50HZ

NOTE — For Temperatures and Capacities not shown in tables, see bulletin — Cooling Unit Rating Table Correction Factor Data in Miscellaneous Engineering Data Section.

## HP29-060 — CB29M-65 - COOLING CAPACITY

Entering Wet Bulb Temperature	Total Air Volume		Outdoor Air Temperature Entering Outdoor Coil																							
			29°C (85°F)						35°C (95°F)						41°C (105°F)						46°C (115°F)					
			Total Cooling Capacity		Comp Motor kW Input	Sensible To Total Ratio (S/T)			Total Cooling Capacity		Comp Motor kW Input	Sensible To Total Ratio (S/T)			Total Cooling Capacity		Comp Motor kW Input	Sensible To Total Ratio (S/T)			Total Cooling Capacity		Comp Motor kW Input	Sensible To Total Ratio (S/T)		
						Dry Bulb						Dry Bulb						Dry Bulb						Dry Bulb		
m <sup>3</sup> /s	cfm	kW	kBtuh	24°C 75°F	27°C 80°F	29°C 85°F	kW	kBtuh	24°C 75°F	27°C 80°F	29°C 85°F	kW	kBtuh	24°C 75°F	27°C 80°F	29°C 85°F	kW	kBtuh	24°C 75°F	27°C 80°F	29°C 85°F	kW	kBtuh	24°C 75°F	27°C 80°F	29°C 85°F
17°C (63°F)	.75	1600	15.4	52.4	4.05	.74	.87	.98	14.8	50.6	4.57	.75	.89	.99	14.3	48.7	5.18	.76	.91	1.00	13.7	46.8	5.87	.77	.92	1.00
	.85	1800	15.6	53.4	4.04	.76	.91	1.00	15.1	51.6	4.57	.77	.92	1.00	14.6	49.7	5.18	.79	.94	1.00	14.0	47.8	5.87	.80	.96	1.00
	.94	2000	15.9	54.4	4.04	.79	.94	1.00	15.4	52.5	4.57	.80	.95	1.00	14.8	50.6	5.17	.82	.97	1.00	14.3	48.7	5.86	.83	.98	1.00
19°C (67°F)	.75	1600	16.4	55.8	4.04	.57	.71	.84	15.8	53.9	4.56	.58	.72	.86	15.2	51.9	5.17	.59	.73	.87	14.6	49.7	5.86	.60	.75	.89
	.85	1800	16.6	56.7	4.04	.59	.74	.88	16.0	54.7	4.56	.59	.75	.89	15.4	52.7	5.17	.60	.76	.91	14.8	50.5	5.86	.61	.78	.93
	.94	2000	16.9	57.5	4.04	.60	.76	.91	16.3	55.5	4.56	.61	.78	.92	15.6	53.4	5.16	.62	.79	.94	15.0	51.2	5.86	.63	.81	.96
22°C (71°F)	.75	1600	17.5	59.6	4.03	.43	.56	.68	16.9	57.6	4.56	.43	.56	.69	16.3	55.5	5.16	.43	.57	.71	15.6	53.3	5.87	.44	.58	.72
	.85	1800	17.8	60.6	4.02	.43	.57	.71	17.1	58.5	4.55	.44	.58	.72	16.5	56.3	5.16	.44	.59	.74	15.8	54.0	5.86	.44	.60	.75
	.94	2000	18.0	61.3	4.03	.44	.59	.74	17.3	59.2	4.55	.44	.60	.75	16.7	57.0	5.16	.45	.61	.77	16.0	54.7	5.86	.45	.62	.79

## HP29-060 — CB29M-65 - HEATING CAPACITY

Indoor Coil Air Volume 21°C db (70°F db)		Air Temperature Entering Outdoor Coil														
		18°C (65°F)			7°C (45°F)			minus 4°C (25°F)			minus 15°C (5°F)			minus 28°C (minus 15°F)		
		Total Heating Capacity		Comp. Motor kW Input	Total Heating Capacity		Comp. Motor kW Input	Total Heating Capacity		Comp. Motor kW Input	Total Heating Capacity		Comp. Motor kW Input	Total Heating Capacity		Comp. Motor kW Input
kW	kBtuh	kW	kBtuh		kW	kBtuh		kW	kBtuh		kW	kBtuh		kW	kBtuh	
.75	1600	18.1	61.6	4.46	14.4	49.1	3.97	10.6	36.2	3.47	7.4	25.2	2.95	3.6	12.4	2.22
.85	1800	18.3	62.4	4.32	14.6	49.9	3.82	10.8	37.0	3.32	7.6	26.0	2.80	3.9	13.2	2.07
.94	2000	18.4	62.8	4.21	14.7	50.3	3.71	11.0	37.4	3.21	7.7	26.4	2.69	4.0	13.6	1.96